



ACUSTICO®
LIGHTING

INSTALLATION INSTRUCTIONS
Wall Light

INSTALLATION INSTRUCTIONS

Wall Light

PARTS:
LED Base incl. DALI inbuilt driver
Sound absorbent shade (attached)

PLEASE NOTE: There are no serviceable parts. Please return to manufacturer for any required repairs.

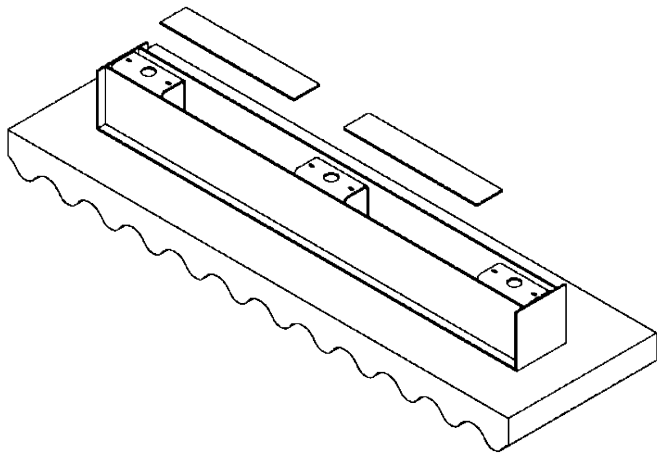

PRE-ASSEMBLY

Ensure there is adequate support in the wall to hold minimum 5 kilograms of weight.

Must be installed by a licensed electrician in accordance with AS/NZS 3000.

Remove aluminium plates from rear of LED base.

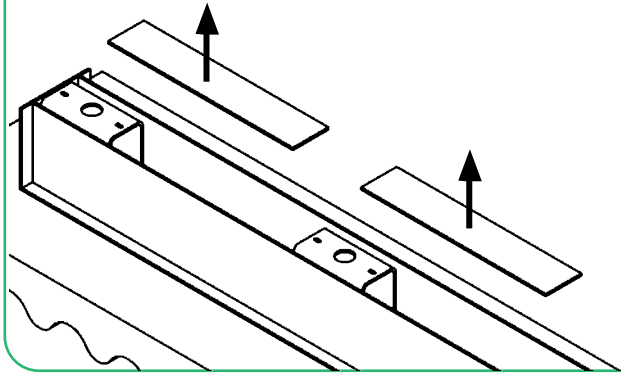

Locate wiring terminal, which connects to driver near the centre of LED base.

Attach mains power to terminal including earth.

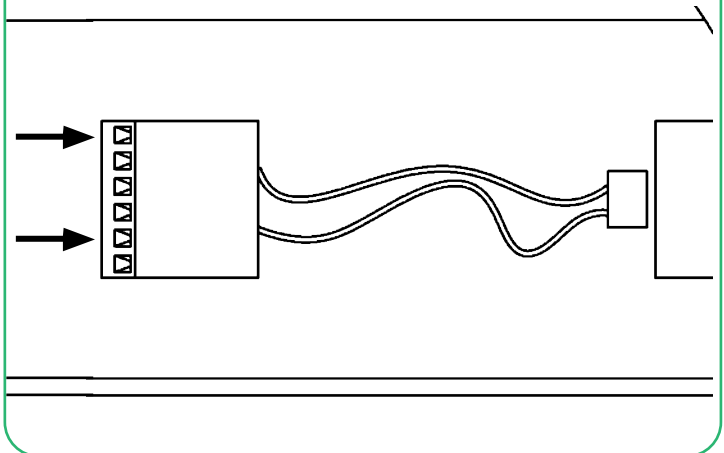

Replace aluminium plates and attach light to wall using steel supports on each end.

